

Glazing Details

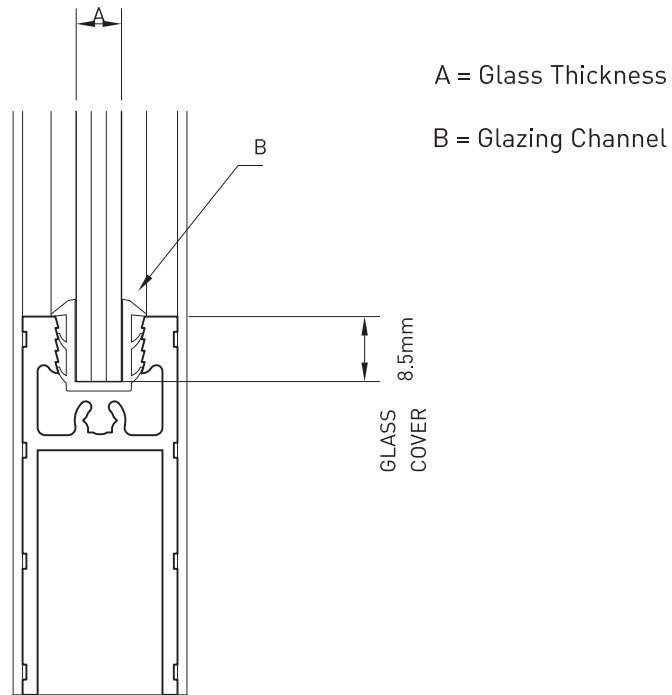

A (Glass Thickness)	B (Glazing Channel)	Material
6mm/6.38mm	04-115	PVC

Note: Maximum Glass Thickness = 6.38mm

Starting from the top centre of glass, assemble channel gasket around glass applying even pressure. Gasket will be required to be slit at corners, taking care not to cut all the way through. Assemble sash framework around glass and gasket. Check assembly for squareness, slight out of squareness may be corrected carefully knocking one corner with a rubber mallet until the assembly becomes square.

Note: Door rollers to be placed in position prior to assembly of door.

