

Sub-Sill Sealing Detail – End Stop

End Stops are required to be installed *BEFORE* fixing sub-sill*

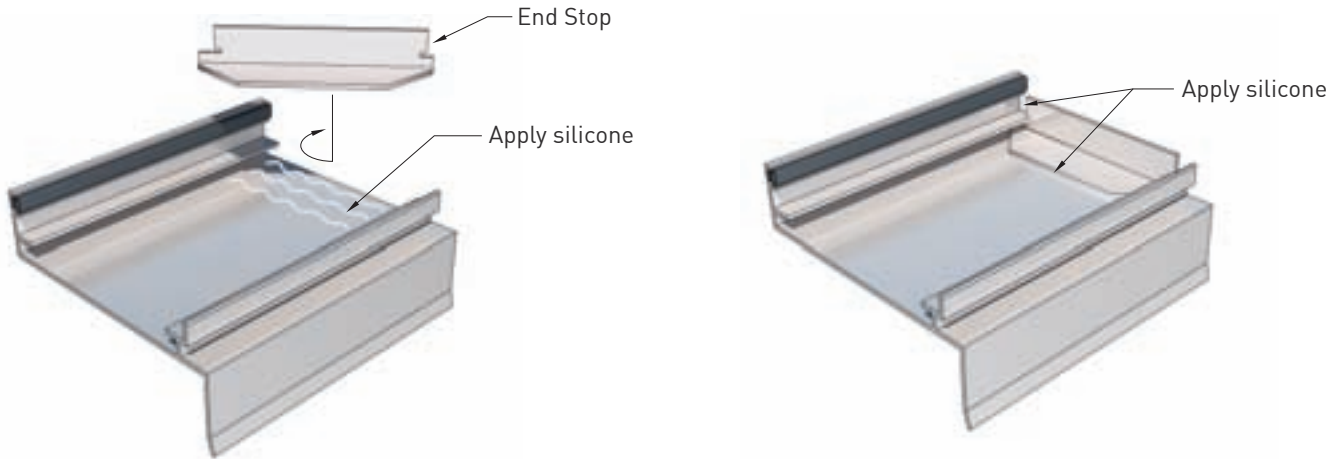

- 1 Cut angle section and machine according to detail drawings. See next page.
Run a bead of silicone around the edges of the sub-sill.

- 2 Apply more silicone sealant to thoroughly seal edges.
Repeat Step 1 and 2 for other end of sub-sill.

Sealing Frame to Sub-Sill

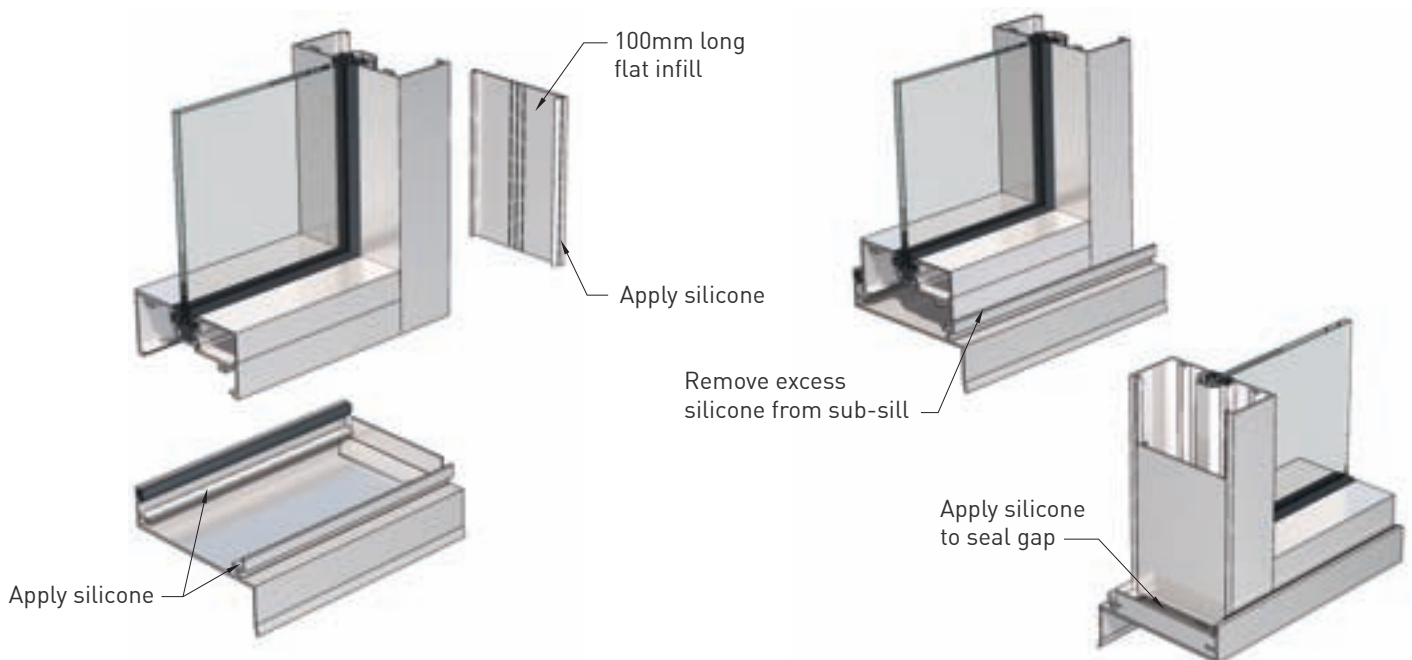

- 1 Apply silicone along the full length of the top face of the sub-sill support legs.
Apply silicone to 100mm long flat infill edges then snap in flat infill to the bottom of both jambs.

- 2 After frame installation clean off any excess silicone. Fill gap between angle end stop and frame with silicone at both ends. Remove excess silicone.

*Please contact Lidco for alternative End Stop installation procedures.

Sub-Sill Sealing Detail – End Stop

Suitable for 400-312

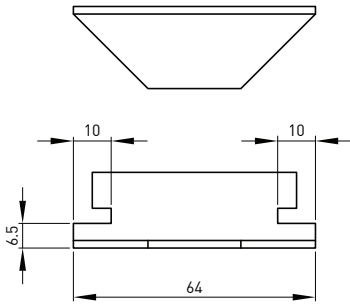

Suitable for 700-247M

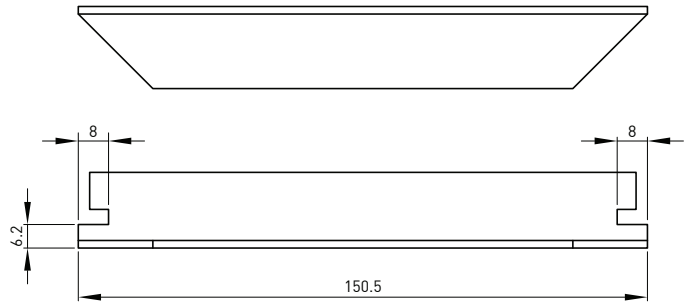

Suitable for 700-431 and 700-429

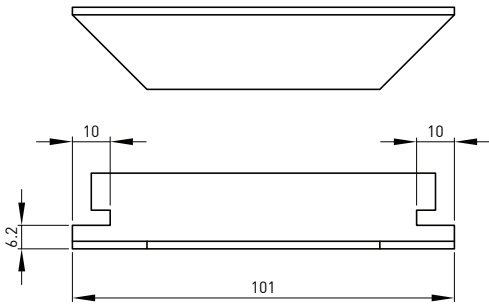

Suitable for 700-247

