



# DuoTherm™

372 System

---

Sliding/Stacking Window

[www.lidco.com.au](http://www.lidco.com.au)



## DuoTherm™ Sliding/Stacking Window – 372 System

Designed for thermal efficiency and style, the DuoTherm™ Sliding /Stacking Window is the perfect solution where energy efficiency and a sleek stylish look are desired. Large panel sizes up to 1.8m high and 1.5m wide are possible, allowing designers to achieve large openings. Thermal efficiency is maximised by the ability to incorporate up to 24mm double glazing and energy savings are further enhanced by the very low air infiltration characteristics of the door due to the unique design of the interlock.

The DuoTherm™ Sliding and Stacking Windows are suitable for a wide range of applications ranging from residential and high end architectural to commercial applications. Expansive openings are further enhanced by the availability of 90° and 135° configurations. In addition, the system is designed to be incorporated into Lidco's vast array of framing systems such that side lights, high lights and low lights can be seamlessly added.

### Better Designed

- + Accepts up to 10mm single glazing and up to 24mm double glazing without the use of unsightly adaptors
- + Low air infiltration due to a full length woolpile on the fixed interlock sealing the top and bottom gaps, making this system ideal for air conditioned buildings
- + Sliding window uses a 100mm frame
- + Optional stacking window uses a 120mm frame
- + Flush looking mortise deadlock
- + Euro-style V-shape sliding track greatly improves the look of the sill
- + Optional durable twin wheel roller with stainless steel bearings and anti-scratch plastic wheels – no paint damage to V-shape track
- + Sash can be used for 100mm bold commercial frame (for sliding window only)
- + All sashes are installed from the inside providing extra security and ease of installation
- + Easily coupled with other Lidco 100mm and 120mm systems

### Options

- + Available with side-lights, high-lights, and low-lights
- + Sump sill
- + 90° and 135° configurations available
- + Flyscreen



Maximum Panel Height <sup>†</sup>	1800mm
Maximum Panel Width <sup>†</sup>	1500mm
Maximum Glass Thickness	≤ 24mm

<sup>†</sup>Dependant on wind loadings, refer to Lidco limitation tables

# Hardware

## Premium Mortise Sliding Window Lock

Premium lock features minimal visual impact to suit today's modern architecture. Innovative hideaway handle allows for low profile mounting on window sash.

- + Innovative hideaway handle for improved visual styling
- + Anti-Slam and Anti-Lift features for added security
- + Snap-on cover plates provide style in a range of colours (standard colour is black).
- + Cover plate conceals the fixing screws for improved security
- + Low profile window lock improves styling and prevents interference with blinds
- + Non-handed latch system suits both left and right handed windows
- + Installation allows for variation in window section width and depth



Premium Mortise Sliding Window Lock

# Detail Features

- + Full length woolpile
- + Optional slimline interlock
- + Euro-style V-shape sliding track
- + Full length sill baffles
- + Optional flyscreen

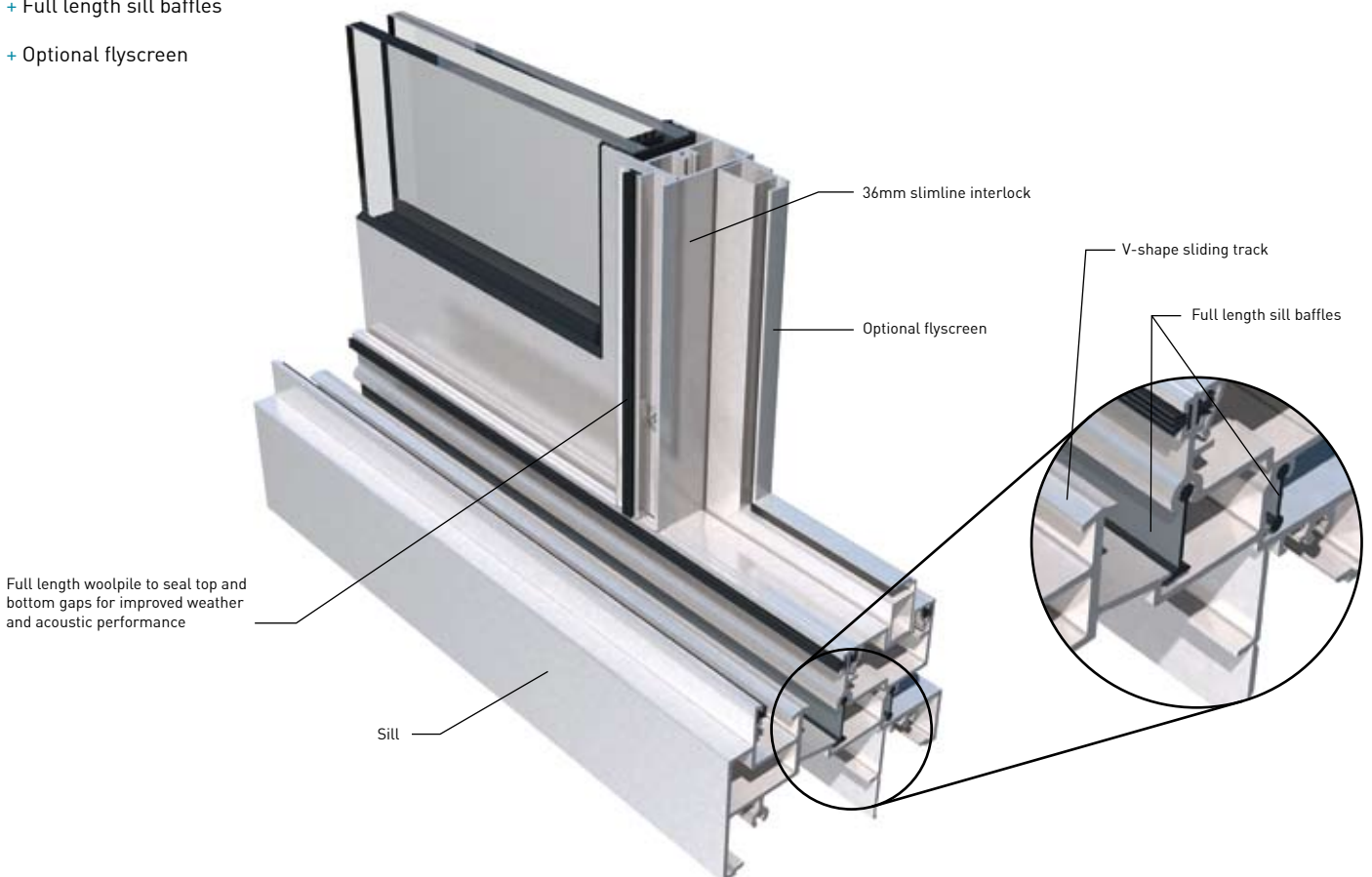

# Design Details

- + Sump sills available for both sliding and stacking windows
- + Full length baffles

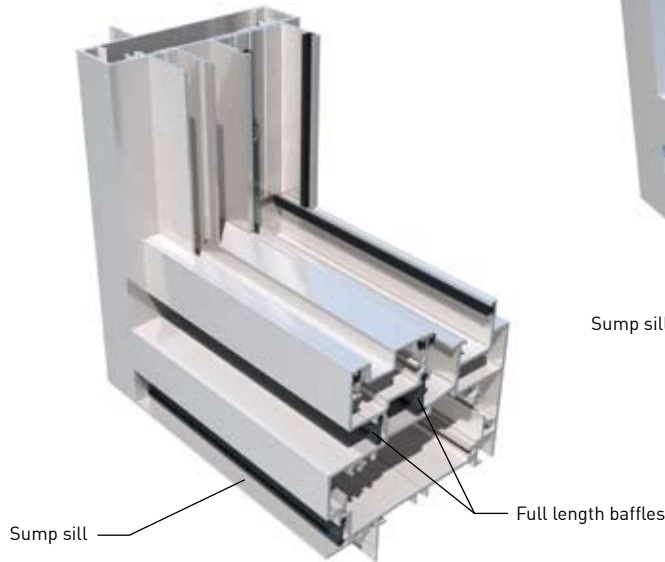

Optional Sliding Window with Sump Sill

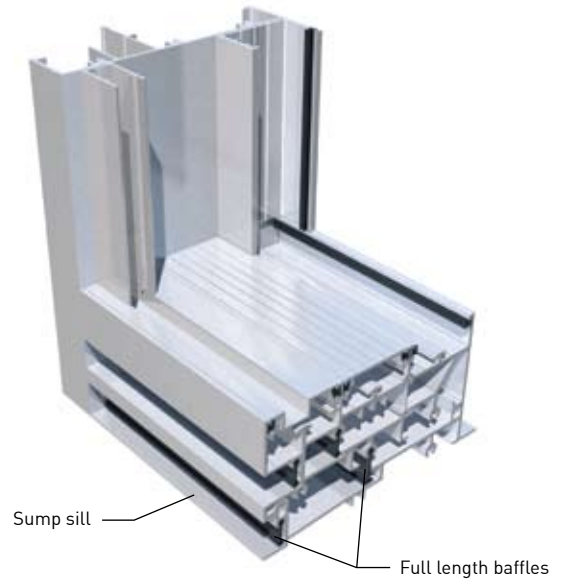

Optional Stacking Window with Sump Sill

# Typical Configurations

## Sliding Window Style

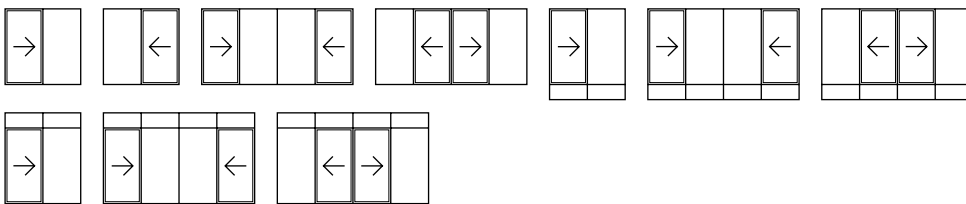

## Stacking Window Style

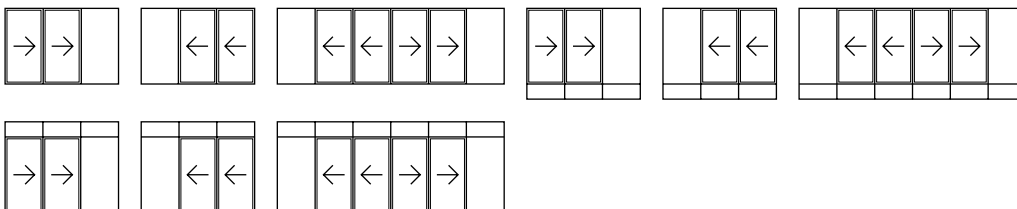

Lidco Corporation Pty Ltd  
 T 1300 663 848  
 www.lidco.com.au

Founded in Australia over 65 years ago Lidco is a leading designer and supplier of contemporary and high performance residential and commercial aluminium window and door systems.

