

Glazing Details

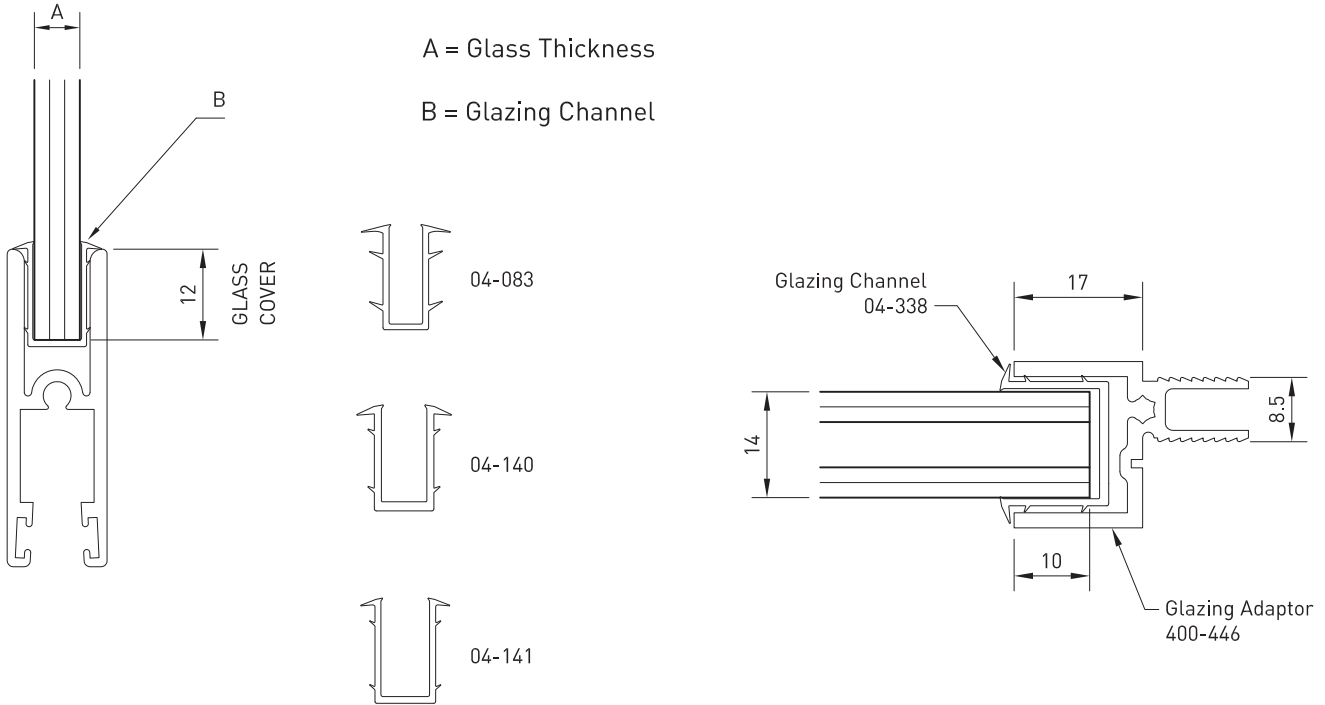

A (Glass Thickness)	B (Glazing Channel)	Material
4mm	04-083	PVC
5mm	04-140	PVC
6mm/6.38mm	04-141	PVC
14mm	04-338	PVC

Starting from the top centre of glass, assemble channel gasket around glass applying even pressure.
Gasket will be required to be slit at corners, taking care not to cut all the way through.
Assemble sash framework around glass and gasket. Check assembly for squareness, slight out of squareness may be corrected by carefully knocking one corner with a rubber mallet until the assembly comes square.

